

JOB REFERENCE \_\_\_\_\_ /s/ \_\_\_\_\_

**SUBMITTAL DATA:**

Qty	Platform/Sensor	Cable Length	Display Increments
		FT	
		M	
		FT	
		M	
		FT	
		M	

WIZARD INDICATOR MODEL NO: \_\_\_\_\_

4-20mA OUTPUTS \_\_\_\_\_

RELAYS \_\_\_\_\_ DRY CONTACT / SOLID STATE  
N.O. / N.C.

OTHER OPTIONS: \_\_\_\_\_

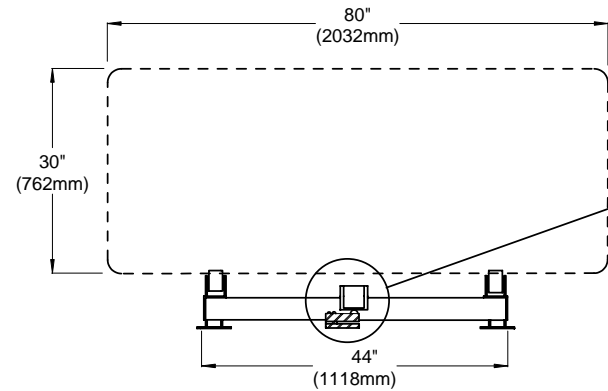

Frame with Welded Round Stock under Tongue (rests on top of other frame)

Frame with Flat Plate (rests on Load Cell)

LOAD CELL

TON CONTAINER

8" (203mm)

MODEL NUMBERS (for Frame & Load Cell)	
DR80	(8000 lbs)
DR40K	(4000 kgs)
MODEL NUMBER (for WIZARD 4000 Indicator)	
4000-1	1-Channel
4000-2	2-Channel
4000-3	3-Channel
4000-4	4-Channel

**IMPORTANT:** Position Load Cell so that it is parallel with the scale frames. Read the installation section carefully for proper placement of the frames.

W.1.121



1150-D Burnett Ave, Concord, CA 94520 USA  
1-800-893-6723 US & Canada, Fax: 925-686-6713  
www.forceflow.com / info@forceflow.com

File: T4\O&M\TON WIZWZ DBL.tcw (TW02.pdf) (WEB: TON2WIZ.pdf)  
EMAIL/DRAWINGS/TON/WIZ DBL.pdf

**ELECTRONIC DUAL TANK SCALE**  
**CHLOR-SCALE with WIZARD INDICATOR**  
(8000 lb or 4000 kg Capacity)

Drawn by: SLP  
Date: 09/01/95  
Revised: 01/27/97  
Scale: NONE

Drawing Number  
**30278**