

STANDARD MODEL (lb)	METRIC MODEL (kg)	# OF CYLINDERS	DESCRIPTION
WR150-1	WR100K-1	1	Single Electronic Cylinder Scale with Single Channel WIZARD 4000 Weight Indicator with 4-20mA Outputs.
WR150-2	WR100K-2	2	Dual Electronic Cylinder Scale with 2-Channel WIZARD 4000 Weight Indicator with (2) 4-20mA Outputs.
WR150-3	WR100K-3	3	Electronic Cylinder Scale with 3-Channel WIZARD 4000 Weight Indicator with (3) 4-20mA Outputs.
WR150-4	WR100K-4	4	Electronic Cylinder Scale with 4-Channel WIZARD 4000 Weight Indicator with (4) 4-20mA Outputs.

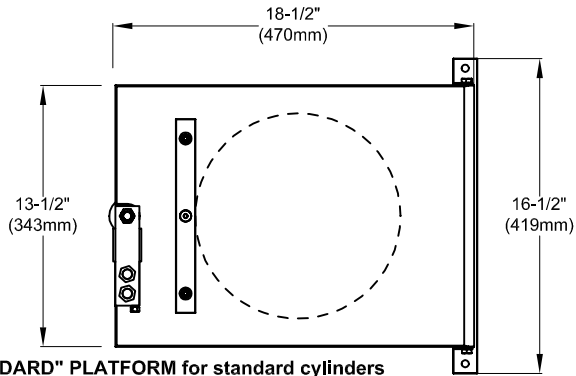

"STANDARD" PLATFORM for standard cylinders

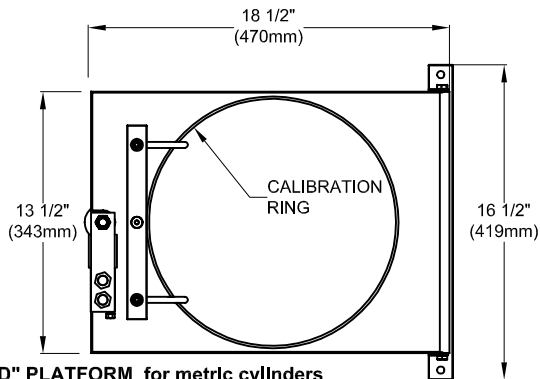

"SLOTTED" PLATFORM for metric cylinders

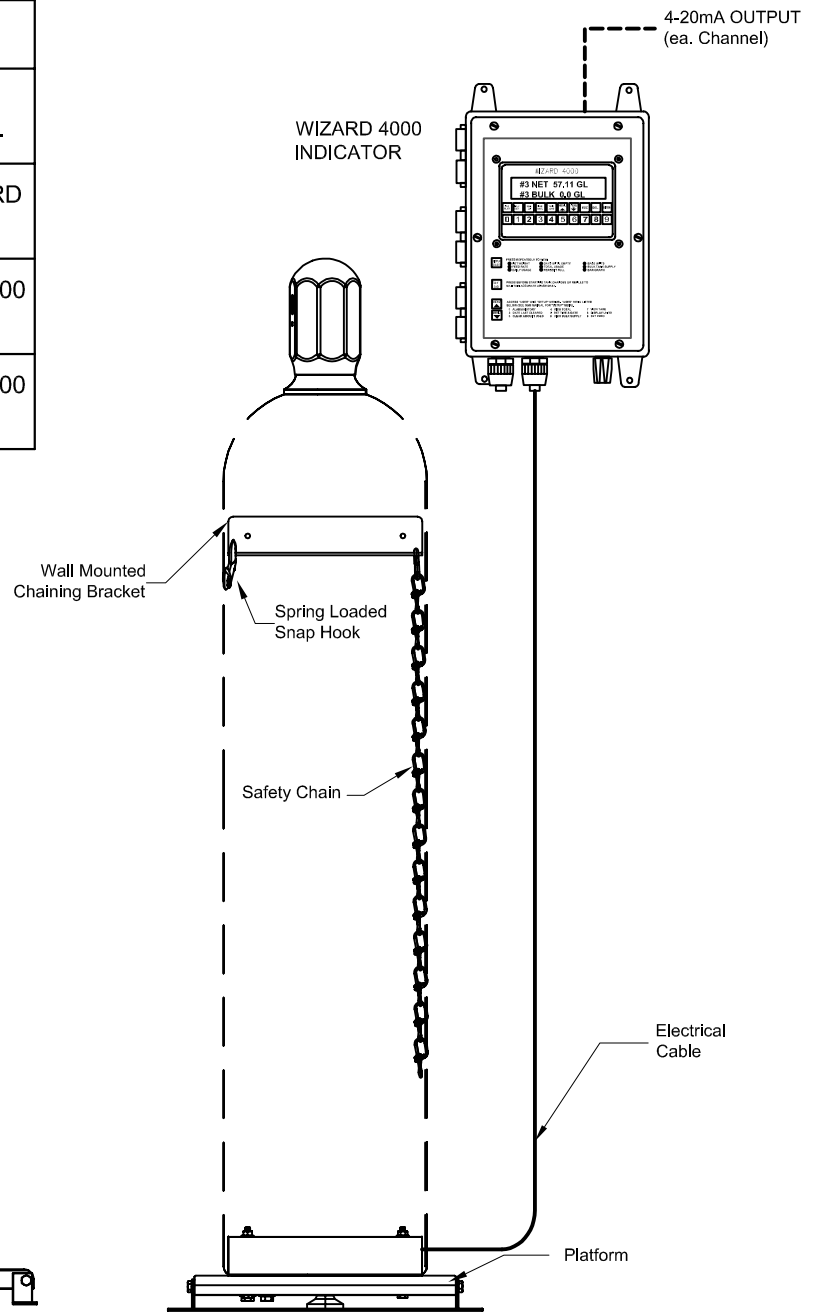
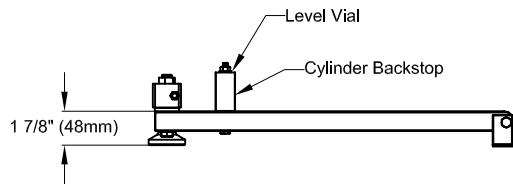

2430 Stanwell Dr, Concord, CA 94520 USA  
 Phone: +1(925)686-6700, 1-800-893-6723  
 www.forceflowscales.com

ELECTRONIC CHLOR-SCALE 150  
 with WIZARD 4000 INDICATOR  
 for Weighing Chlorine &  
 Sulfur Dioxide Cylinders

Drawn by: KBV

Date: 9/24/19

Revised:

Revision #:

Drawing Number

32009