

STANDARD MODEL (lb)	METRIC MODEL (kg)	DESCRIPTION
GR150-2	GR100K-2	Dual Electronic Cylinder Scale with Dual Channel SOLO G2 Weight Indicator with 4-20mA Outputs.

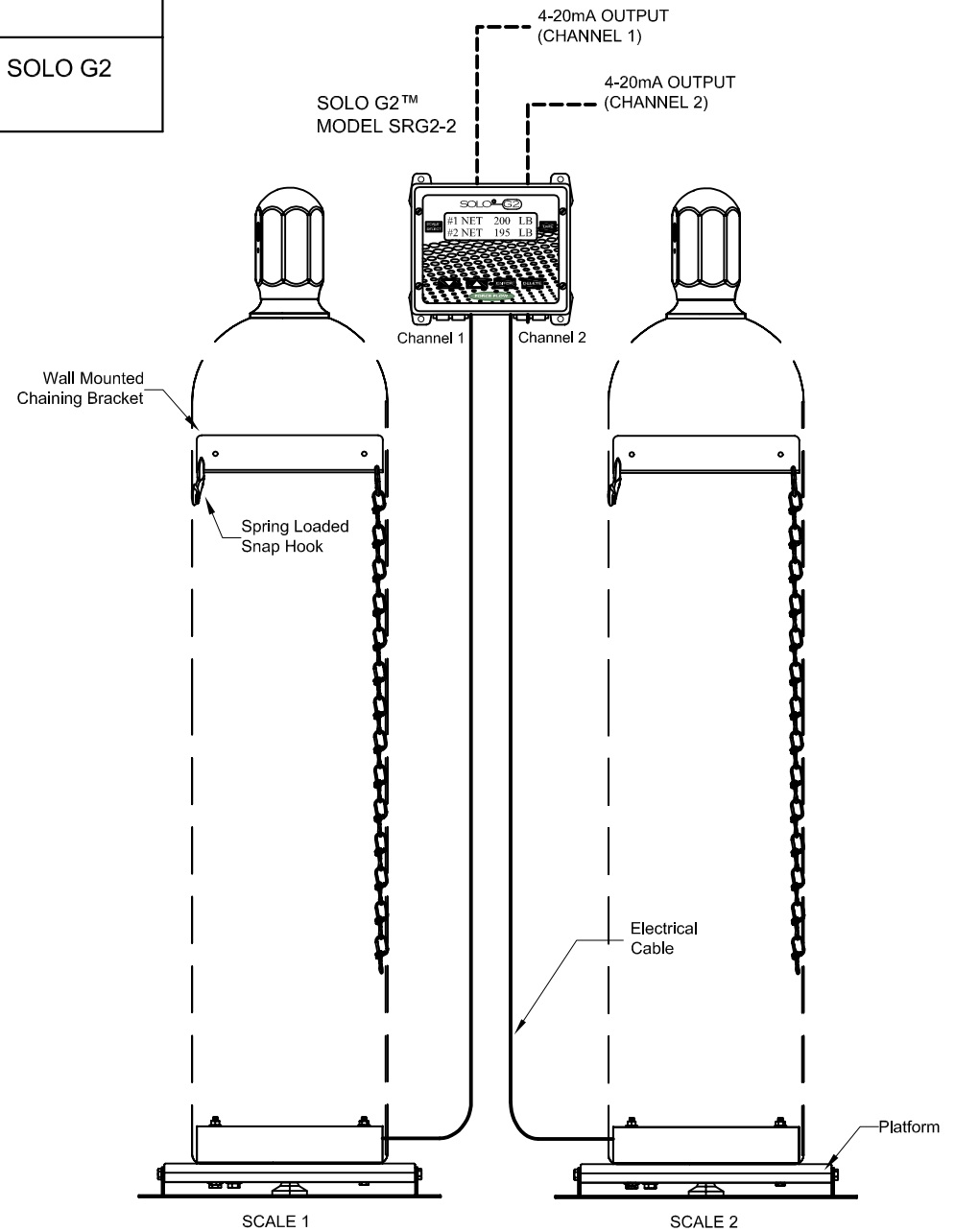
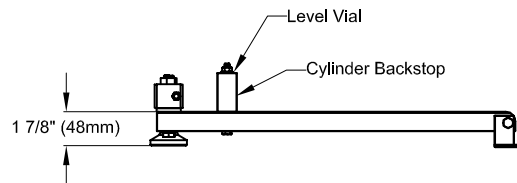
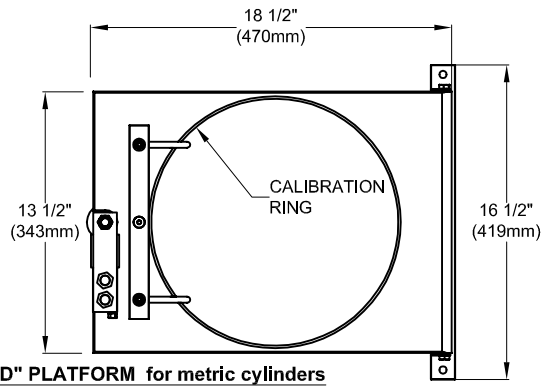
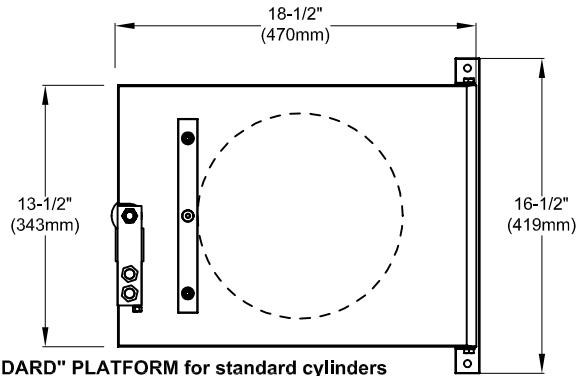

2430 Stanwell Dr, Concord, CA 94520 USA
 Phone: +1(925)686-6700, 1-800-893-6723
 www.forceflowscales.com

DUAL ELECTRONIC
 CHLOR-SCALE 150™ with
 SOLO G2™ INDICATOR
 for 150 LB CYLINDERS

Drawn by: KBV
 Date: 9/24/19
 Revised:
 Revision #:

Drawing Number

32007